

Product features and decorations may vary from photo above.

## Instructions

Model Number: H4790



## WARNING

**IMPORTANT! KEEP FOR FUTURE REFERENCE.**

Please read these instructions before assembly and use of this product.  
Adult assembly is required. Tool needed for assembly: Phillips Screwdriver (not included).



[www.fisher-price.com](http://www.fisher-price.com)



## **WARNING**

**Prevent serious injury or death from falls or sliding out:**

- The child should at all times wear a safety harness correctly fitted and adjusted. The tray is not designed to hold the child in the chair.
- Always keep child in view while in the high chair.
- Never leave child unattended.
- It is recommended that the high chair be used in the upright position only by children capable of sitting upright unassisted.



## **CAUTION**

This product contains small parts in its unassembled state.  
Adult assembly is required.

# Parts

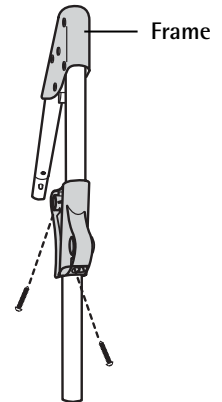
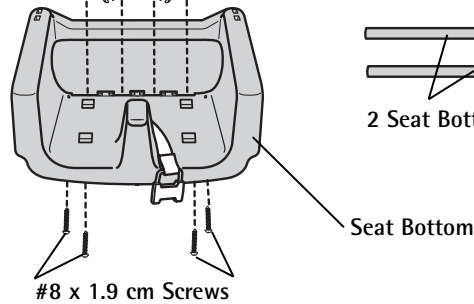
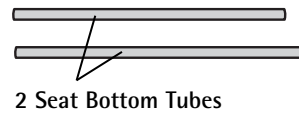
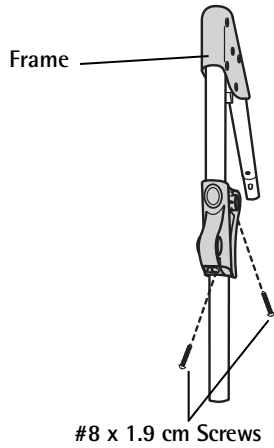
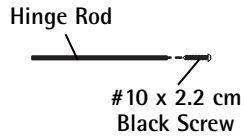
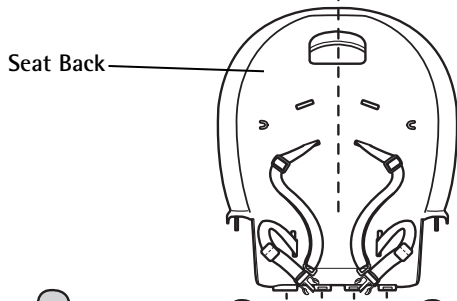
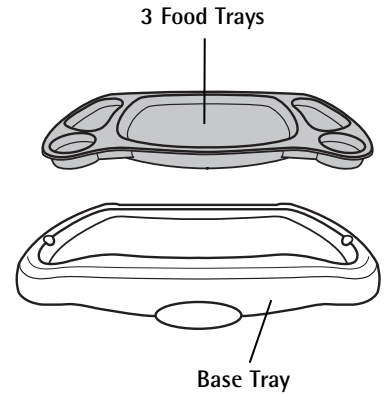
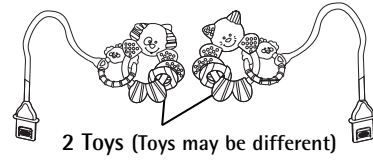
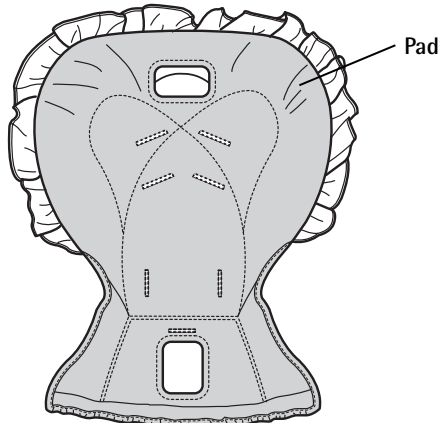
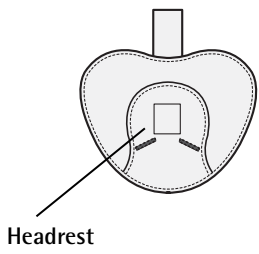

#8 x 1.9 cm Screws

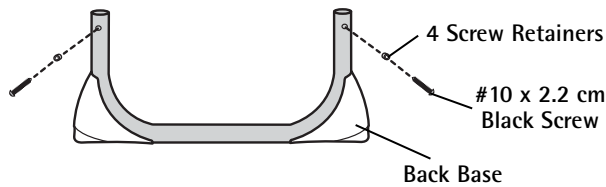

Footrest

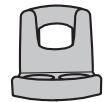

Front Base

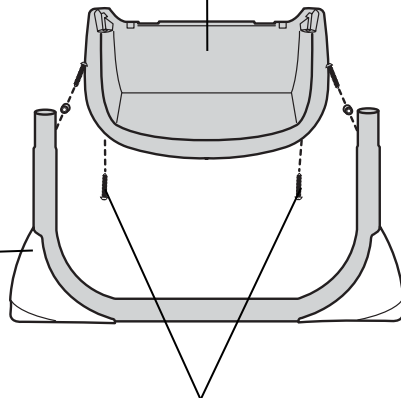

Tighten and loosen all screws with a Phillips screwdriver. Do not over-tighten the screws.



#8 x 1.9 cm Screw - 8



#10 x 2.2 cm Black Screw - 7

Shown Actual Size

# Assembly

**IMPORTANT!** Before each use, inspect this product for damaged hardware, loose joints, missing parts or sharp edges. DO NOT use if any parts are missing or broken. Contact Mattel for replacement parts and instructions if needed. Never substitute parts.

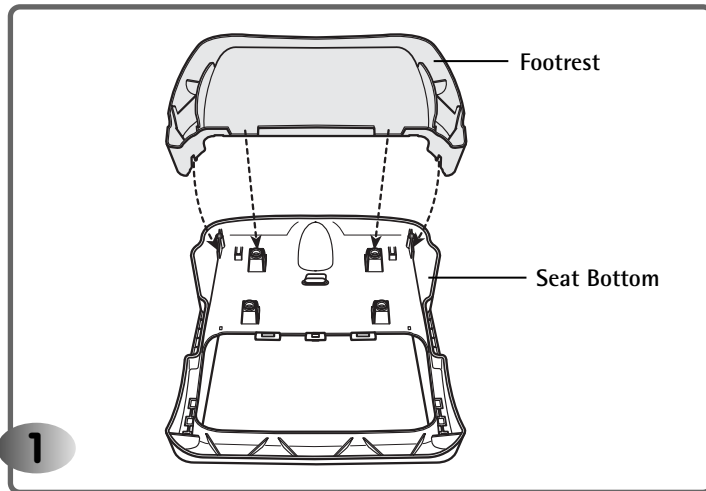

- Place the seat bottom face down on a flat surface.
- At an angle, fit the footrest on the seat bottom, as shown.

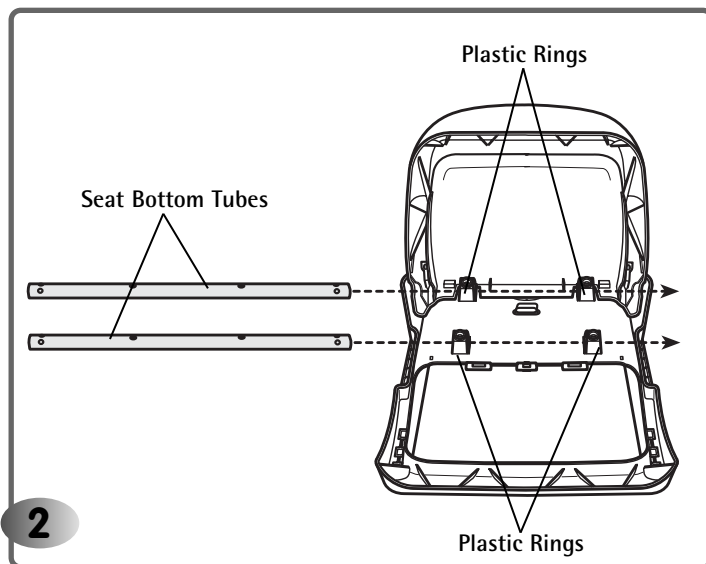

- Slide a seat bottom tube through each set of plastic rings on the seat bottom.

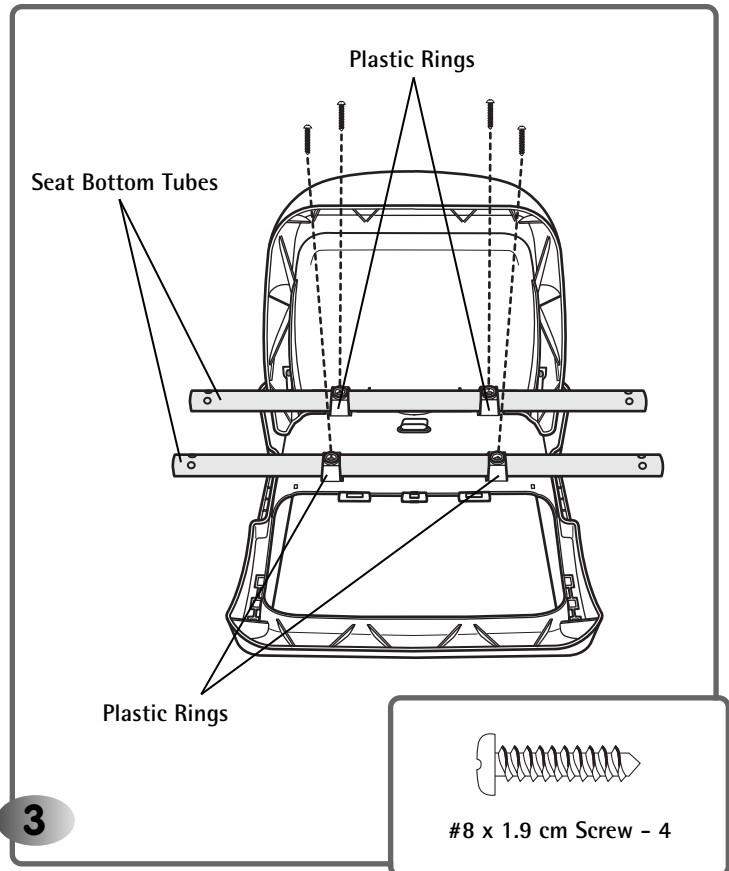

- Align the holes in the plastic rings and the seat bottom tubes.
- Insert a #8 x 1.9 cm screw through each plastic ring and into the seat bottom tubes, as shown. Tighten the screws.
- Push the seat bottom tubes back and forth to be sure they are secured to the seat bottom. If the seat bottom tubes move, you have probably not fastened them properly. Remove the screws and check to be sure the screw holes in the seat bottom tubes and seat bottom plastic rings are aligned. Replace and tighten the screws.

# Assembly

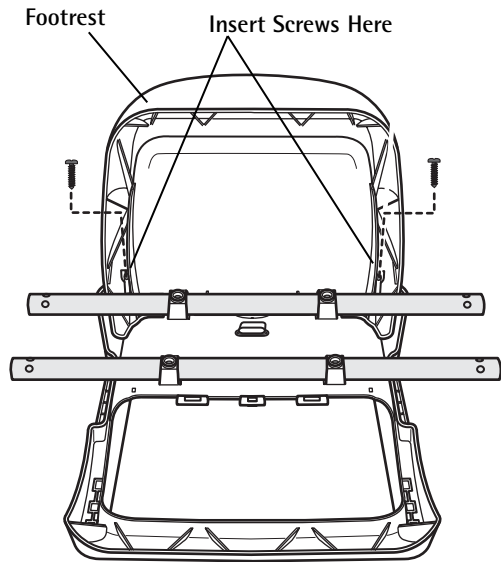

4

#10 x 2.2 cm Black Screw - 2

- Insert two #10 x 2.2 cm black screws through the footrest and into the seat bottom. Tighten the screws.

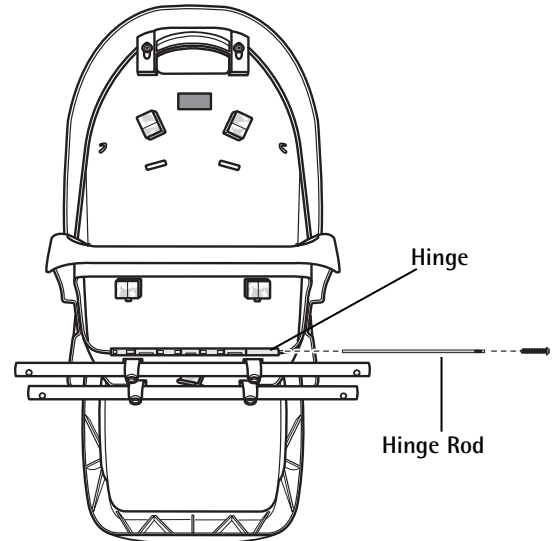

6

#10 x 2.2 cm Black Screw

- Turn the seat assembly face down.
- Insert the hinge rod through the hinge on the seat back and seat bottom, as shown.
- Insert a #10 x 2.2 cm black screw into the hinge rod. Tighten the screw.
- Set the seat assembly aside for Assembly step 9.

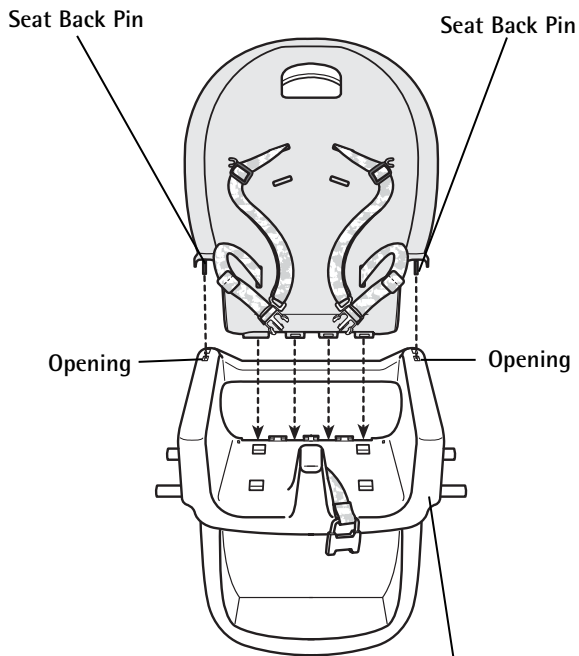

5

Seat Bottom Assembly

- Turn the seat bottom assembly upright.
- Fit the seat back pins into the openings in the top side of the seat bottom assembly.

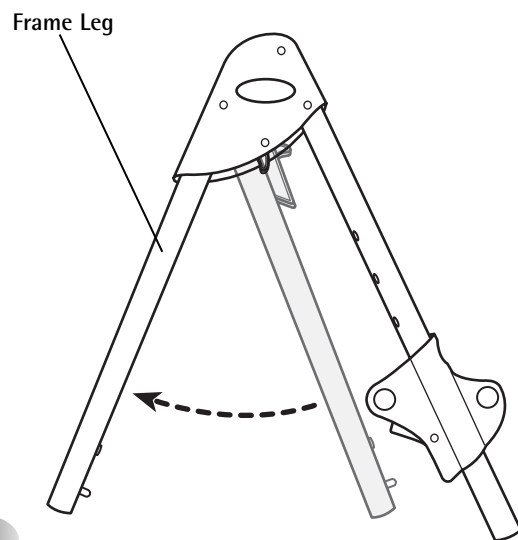

7

- Pull the frame leg out on each frame to open. Make sure it "clicks" into place.

# Assembly

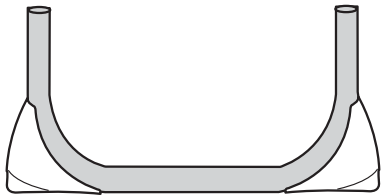

Back Base

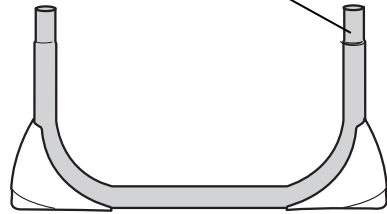

Front Base

8

- Identify the back and front base. The front base has tapered leg tubes. You will use the back base for the next assembly step.

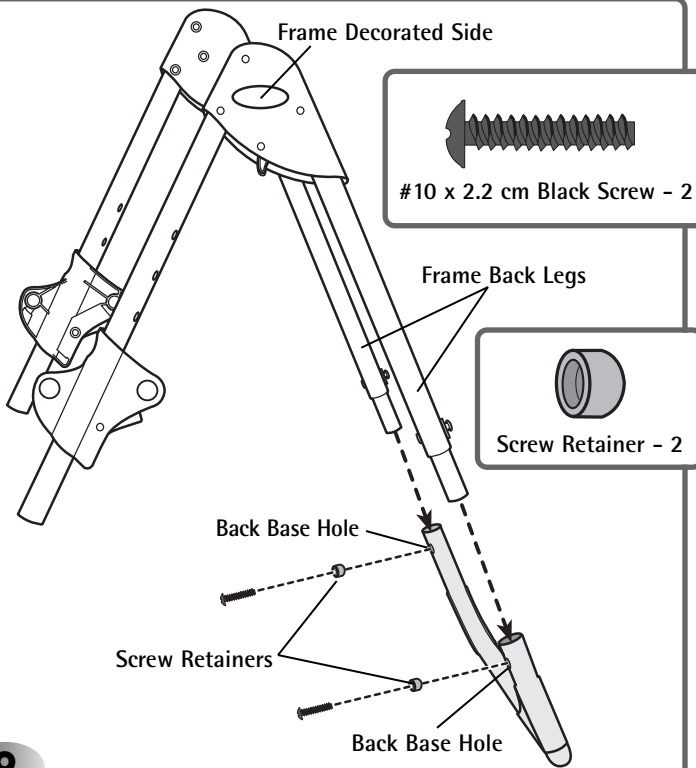

9

- Position a frame so that the decorated side is outward.
- Insert the back leg of a frame into the back base.
- Fit a screw retainer over the hole in the back base, as shown.
- Insert a #10 x 2.2 cm black screw through the screw retainer and back base. Insert the back leg of a frame into the back base. Tighten the screw.
- Repeat this procedure to attach the other frame back leg to the other side of the back base.

**Hint:** The #10 x 2.2 cm black screws may have been assembled to the screw retainers.

Seat Height Adjusters

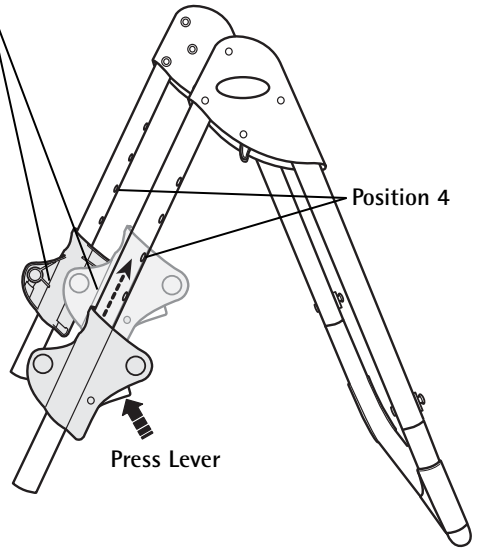

10

- While pressing the levers on the seat height adjusters, lift them to position 4 on the frame front legs, as shown.

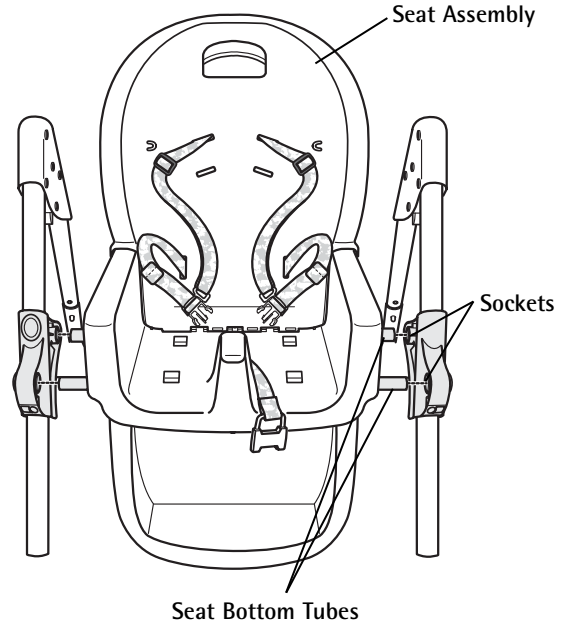

11

- Fit the seat assembly between the two frames.
- Insert the seat bottom tubes into the sockets in each seat height adjuster.

**Hints:**

- Be sure the seat height adjusters are in the same position (position 4).
- You may need to push the frames apart slightly to fit the seat bottom tubes into the seat height adjuster sockets.

## Assembly

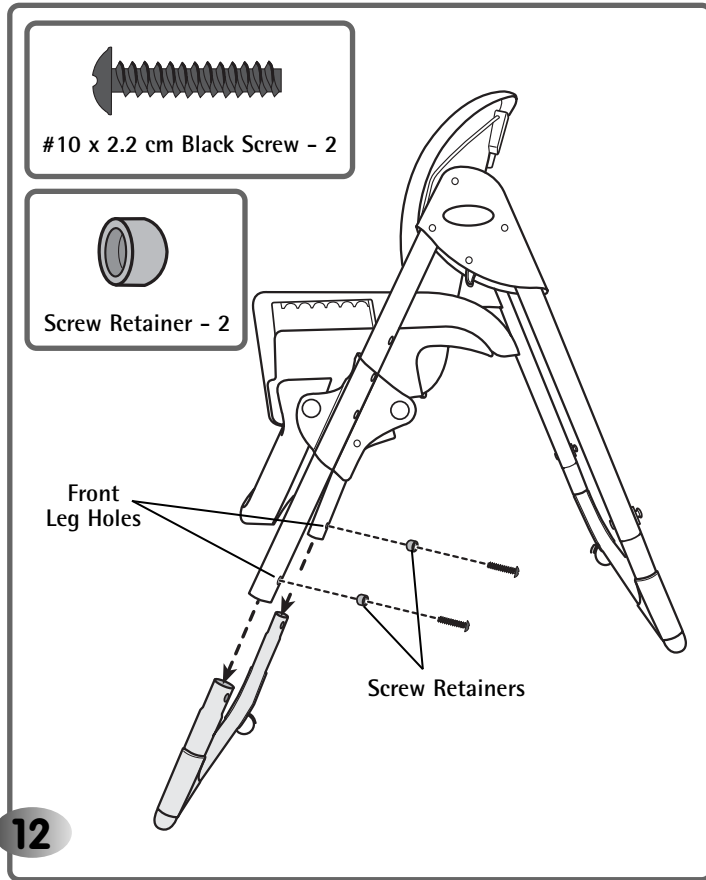

- Insert the frame front legs onto the front base.
- Fit a screw retainer over a hole in the front leg.
- Insert a #10 x  $\frac{7}{8}$ " (2.2 cm) black screw through the screw retainer and front leg. Tighten the screw.
- Repeat this procedure to secure the other end of the front base with the remaining screw retainer and #10 x 2.2 cm black screw.

**Hint:** The #10 x 2.2 cm black screws may have been assembled to the screw retainers.

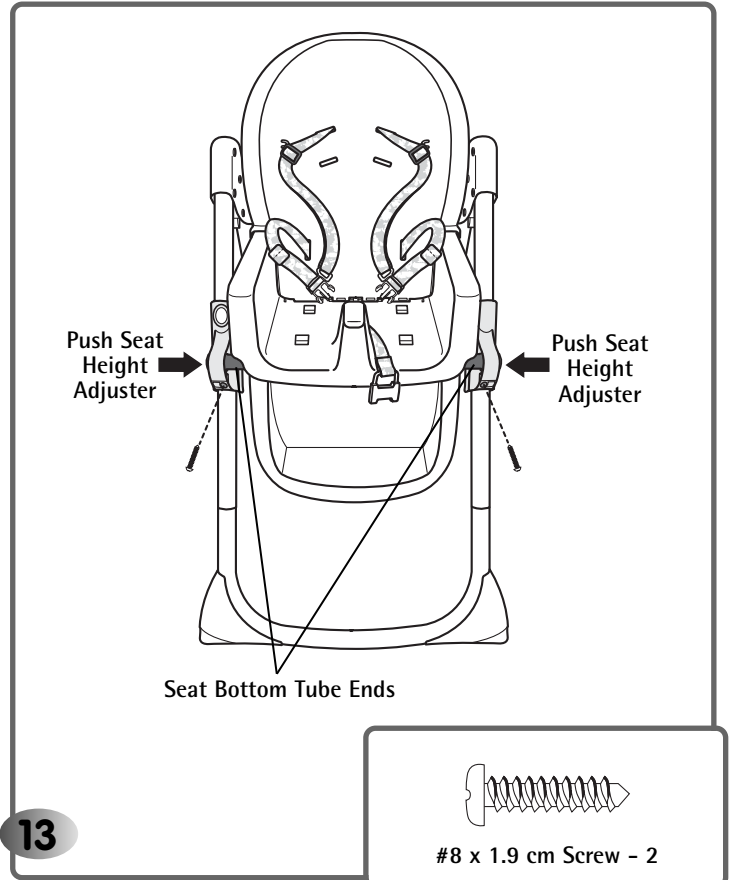

- Push each seat height adjuster to be sure they are completely on the seat bottom tubes.
- Insert a #8 x 1.9 cm screw through each seat height adjuster and the ends of the seat bottom tube. Tighten the screws.

# Assembly

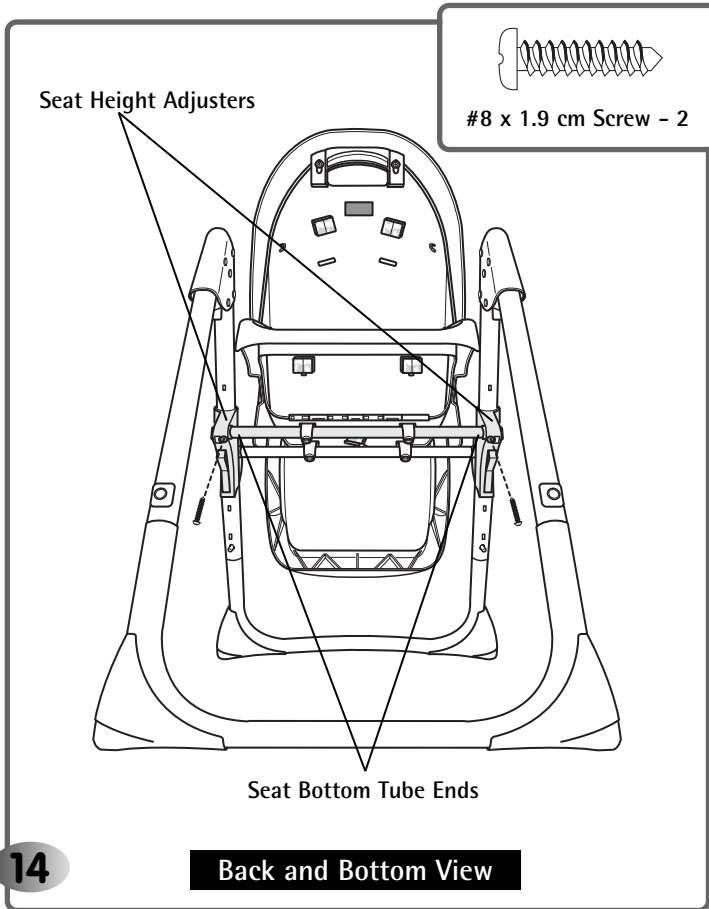

- From the back and bottom of the assembly, insert a #8 x 1.9 cm screw through both seat height adjusters and the ends of the seat bottom tube. Tighten the screws.

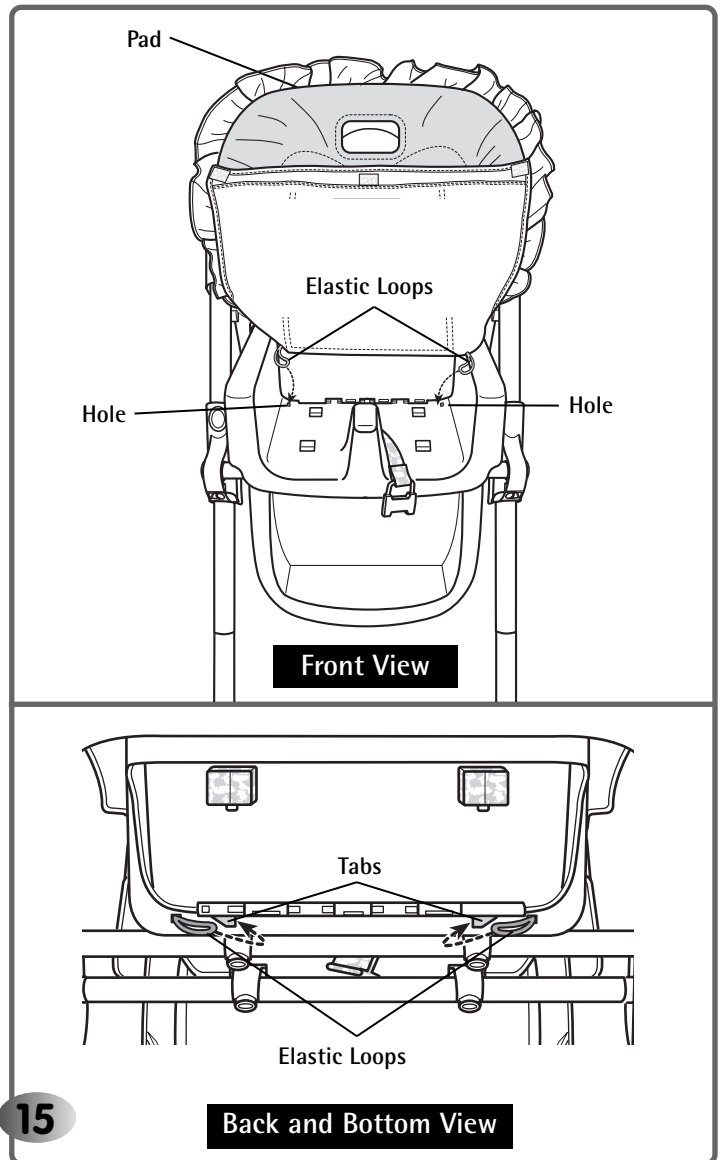

- Lift the assembly upright.
- From the front of the assembly, place the pad onto the seat.
- Lift the bottom of the pad. Insert the two elastic loops on the pad through the holes in the seat bottom.
- From the back and bottom of the seat, hook the elastic loops to the tabs on the seat.



## Assembly

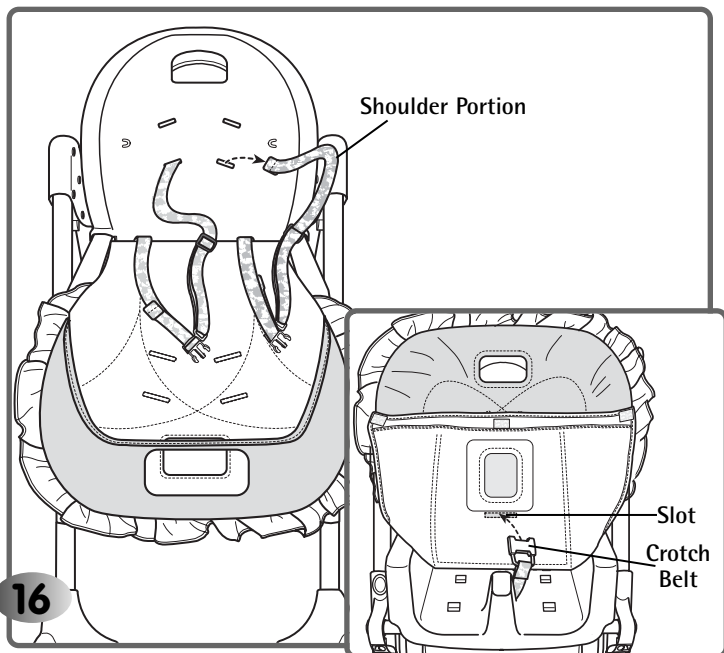

- 16
- Insert the crotch belt through the slot in the pad. Make sure the crotch belt is not twisted.
  - Fold the top of the pad down.
  - Remove the shoulder portion of the waist/shoulder belts by feeding them through the slots in the seat back.

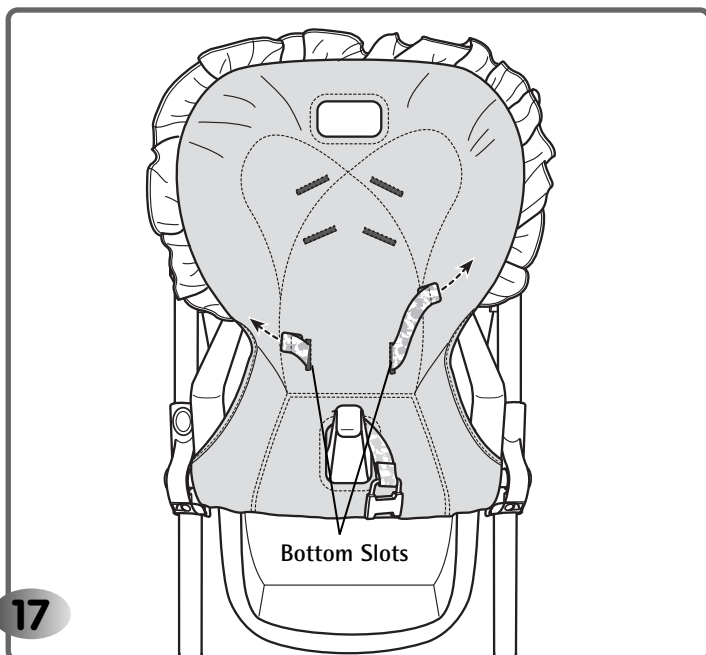

- 17
- Lift the top of the pad.
  - Thread the waist/shoulder belts through the bottom slots in the back of the seat pad.

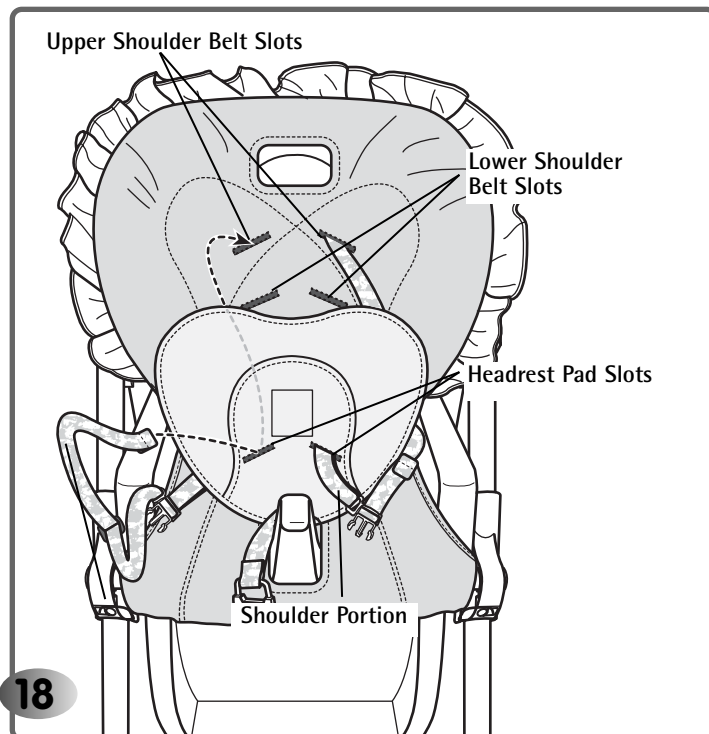

- 18
- Fit the top of the pad over the seat back.
  - Fold the bottom edge of the pad under the edge of the seat bottom to fasten it.
  - First, insert the shoulder portion of the shoulder/waist belt through the slots in the headrest pad. Then, insert the shoulder portion of the shoulder/waist belt through the slots in the pad **and** seat back.
    - Use the **lower** shoulder belt slots for a smaller baby.
    - Use the **upper** shoulder belt slots for a larger baby.

# Assembly

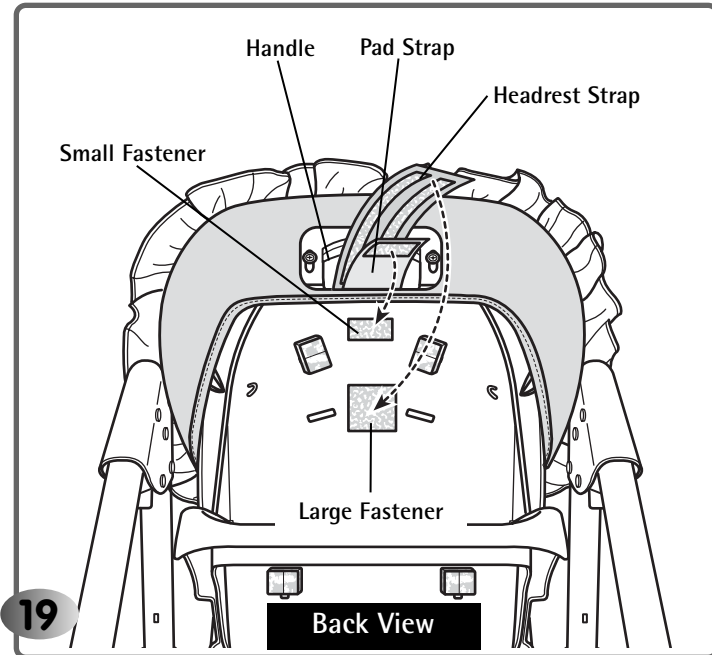

- Fit the strap on the top of the headrest through the handle.
- Fit the pad strap through the handle and press it to the small fastener on the back of the seat.
- Fit the headrest strap through the handle and press it to the large fastener on the back of the seat.

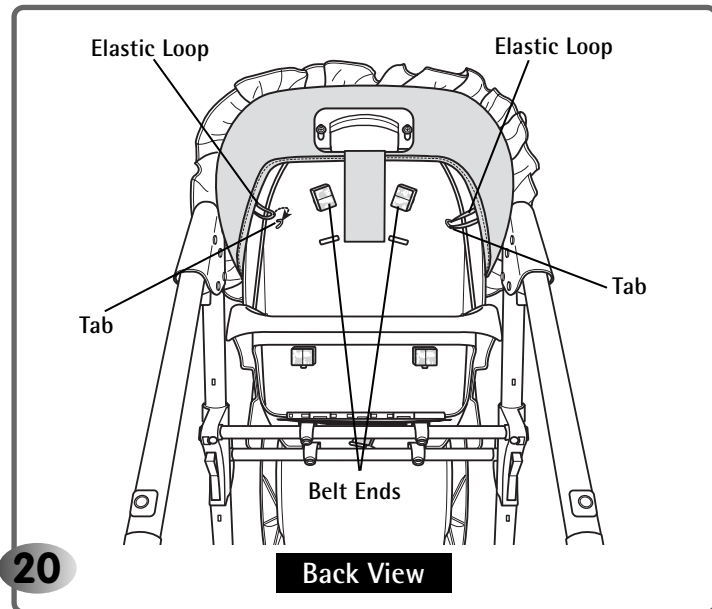

- From behind the seat, be sure the shoulder portion of the waist/shoulder belts are secure in the seat back slots.
- Hook the elastic loops on each side of the pad onto the tabs in the seat back.

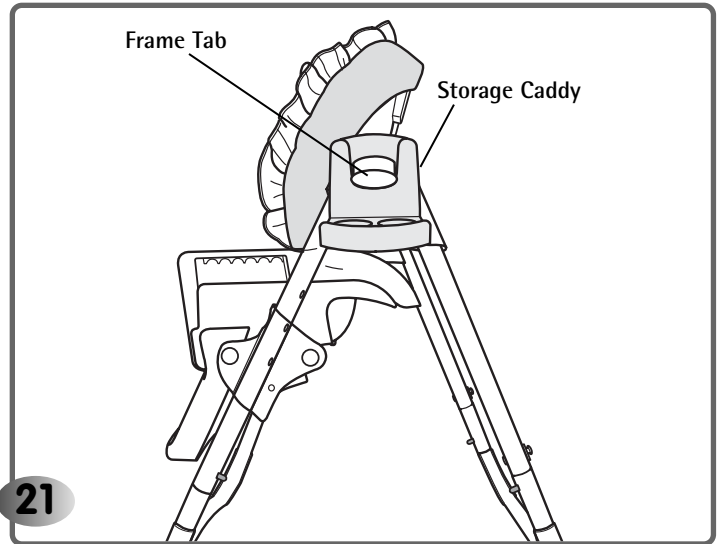

- Fit the storage caddy onto either frame tab.

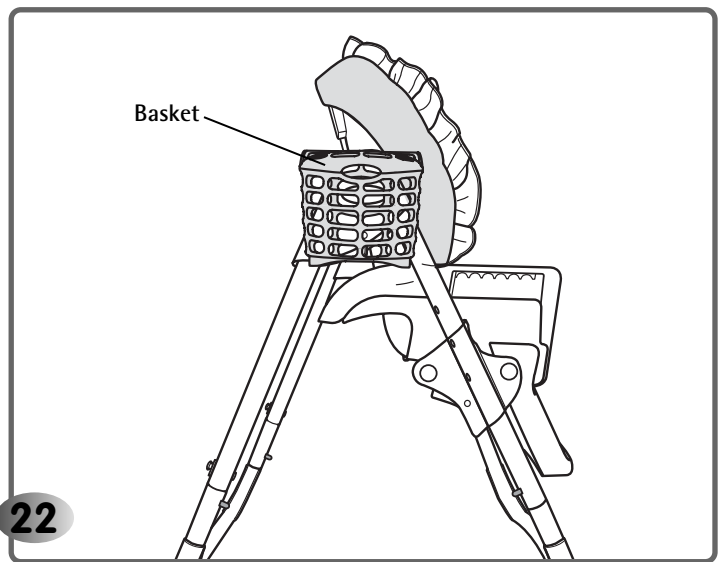

- Fit the basket onto the other frame tab.
- Assembly is now complete.

## Securing Your Child

**IMPORTANT!** Before each use, inspect this product for damaged hardware, loose joints, missing parts or sharp edges. DO NOT use if any parts are missing or broken. Contact Mattel for replacement parts and instructions if needed. Never substitute parts. Place the high chair on a level, stable surface away from electrical flexes. Be sure to keep electrical flexes out of child's reach.

### WARNING

**Prevent serious injury or death from falls or sliding out.** The child should at all times wear a safety harness correctly fitted and adjusted. The tray is not designed to hold the child in the chair.



- Place your child in the seat. Position the crotch belt between your child's legs.
- Fasten both waist/shoulder belts to each side of the crotch belt. Make sure you hear a "click" on both sides.
- Check to be sure the restraint system is securely attached by pulling it away from your child. The restraint system should remain attached.

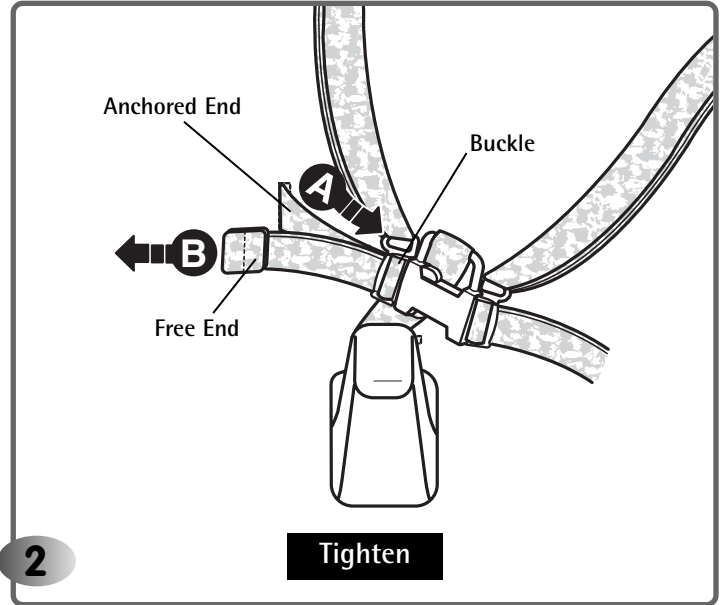

To tighten the waist belts: Feed the anchored end of the waist belt up through the buckle to form a loop **A**. Pull the free end of the waist belt **B**.

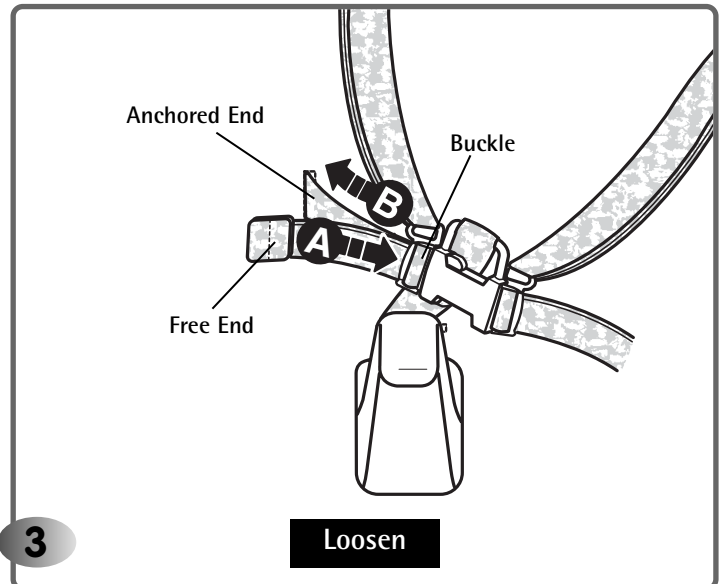

To loosen the waist belts: Feed the free end of the waist belt up through the buckle to form a loop **A**. Enlarge the loop by pulling on the end of the loop toward the buckle. Pull the anchored end of the waist belt to shorten the free end of the waist belt **B**.

## Securing Your Child

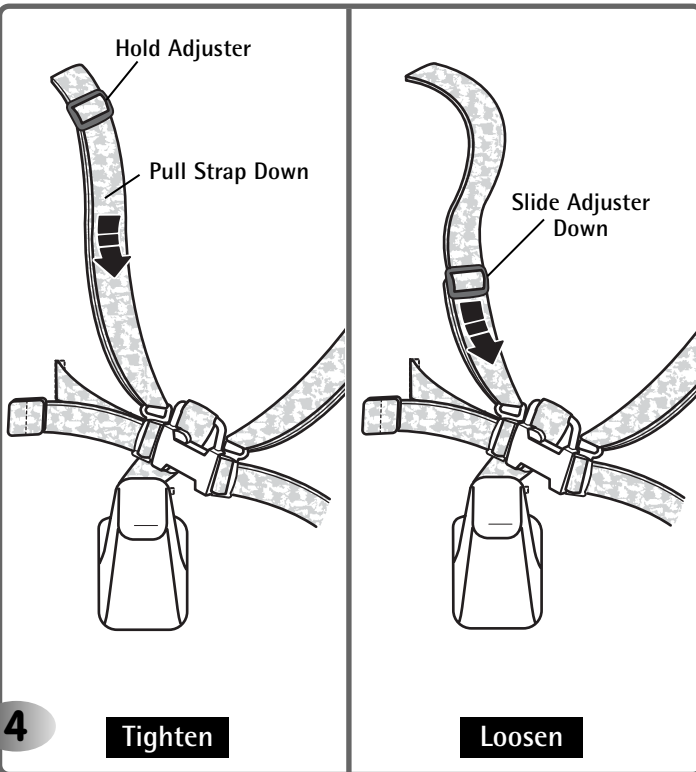

- To tighten the shoulder belts: Hold the adjuster and pull the front shoulder strap down.
- To loosen the shoulder belts: Slide the adjuster down.

**Note:** After adjusting the restraint system to fit your child, make sure you pull on it to be sure it is securely fastened.

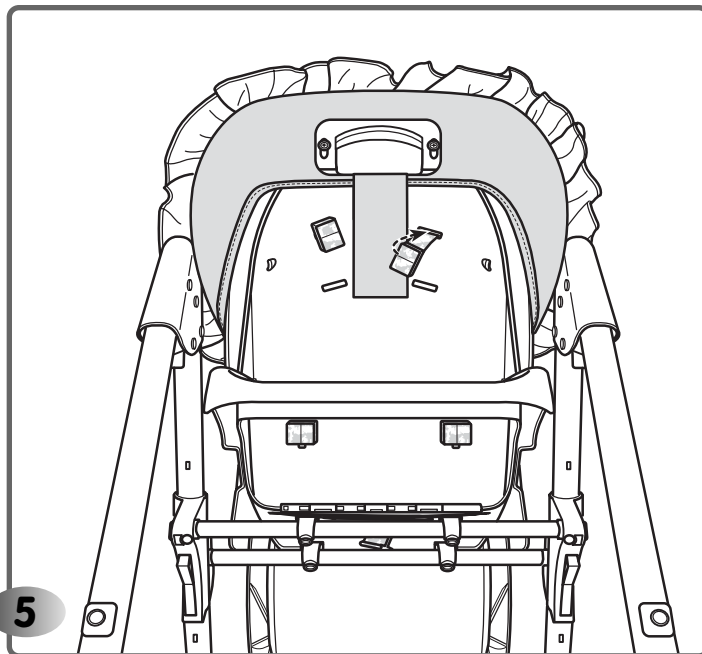

### To change shoulder belt slots:

- From the back of the high chair, push the shoulder portion of the waist/shoulder belts through the seat back slots.

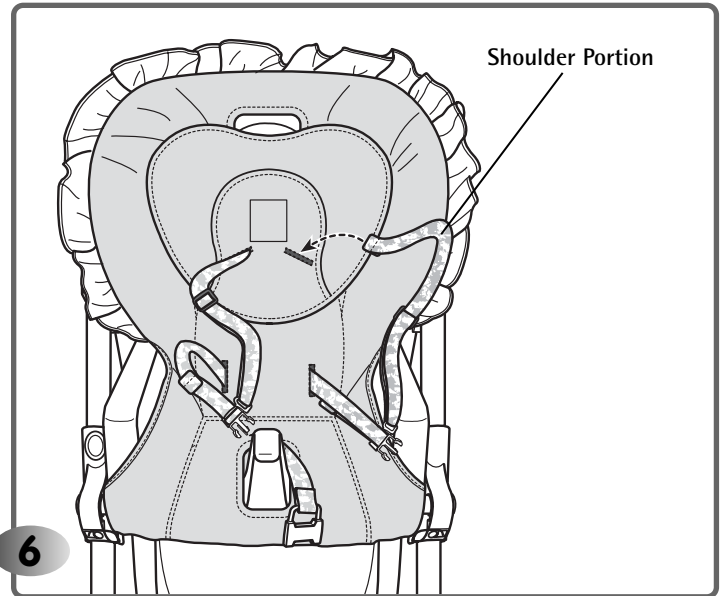

- From the front of the high chair, pull the shoulder portion of the waist/shoulder belts out and then fit them back through the desired shoulder belt slots in the headrest pad, seat pad and the seat back. Pull on the belts to be sure they are secure in the seat back.

## Using the Trays and Toys

### WARNING

Prevent serious injury or death from falls or sliding out. The child should at all times wear a safety harness correctly fitted and adjusted. The tray is not designed to hold the child in the chair.

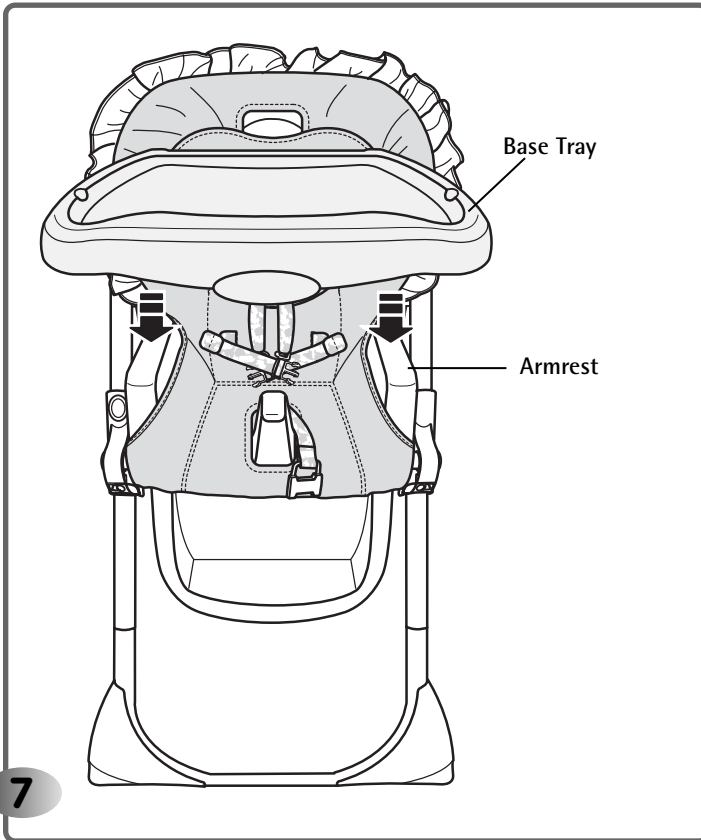

- Fit the base tray onto the seat armrests. Push down until the base tray "snaps" into place.

**Hint:** Before use, thoroughly wash all parts (the trays) that may contact food.

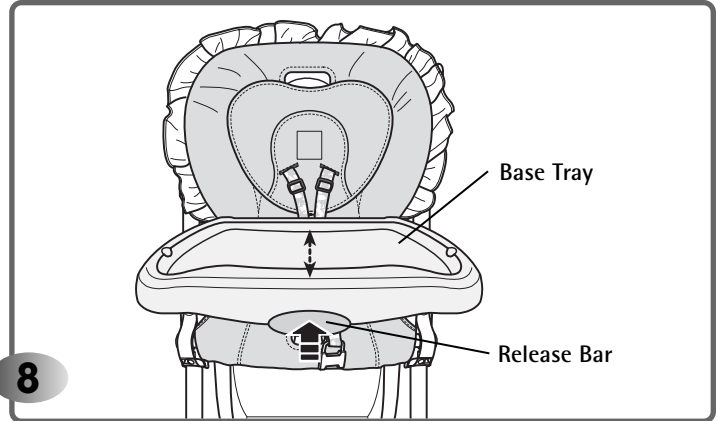

**Hint:** The base tray can be adjusted for your child's comfort two ways (see steps 8 and 9)!

- While pushing the release bar on the front of the base tray, adjust the base tray forward or backward.

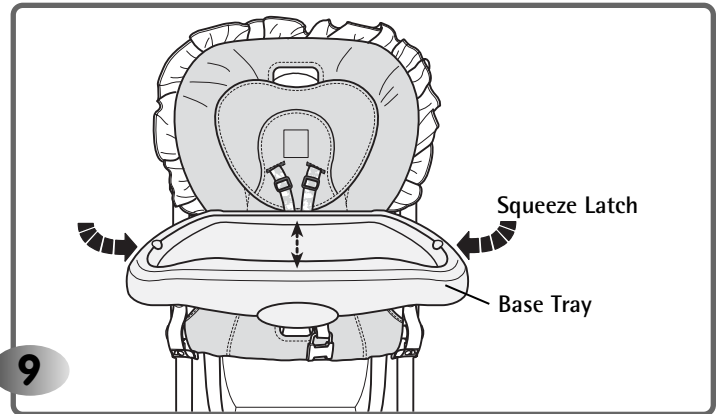

- While squeezing the latches underneath the base tray, adjust the base tray forward or backward.

## Using the Trays and Toys

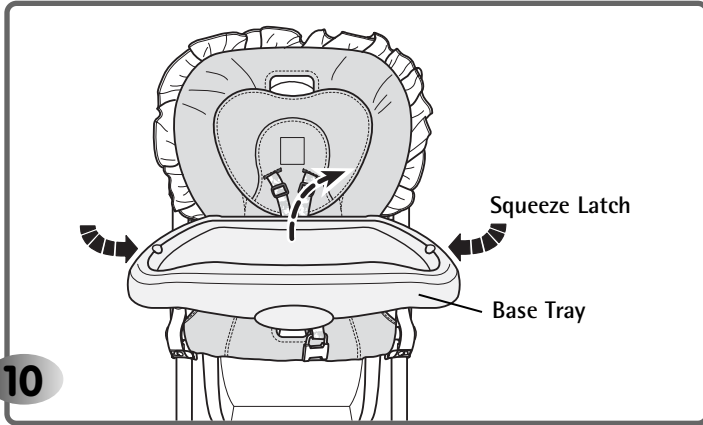

**Hint:** The base tray can be removed two ways (see steps 10 and 11)!

- Squeeze one or both of the latches underneath the base tray and lift.

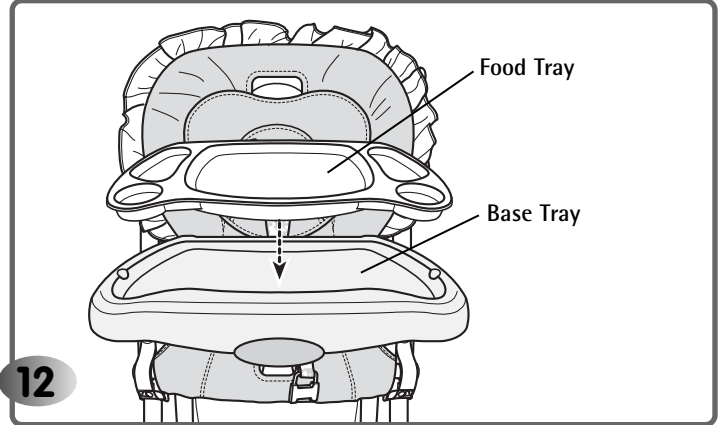

- Fit the food tray into the base tray, as shown.

**Hint:** Before use, thoroughly wash all parts (the trays) that may contact food.

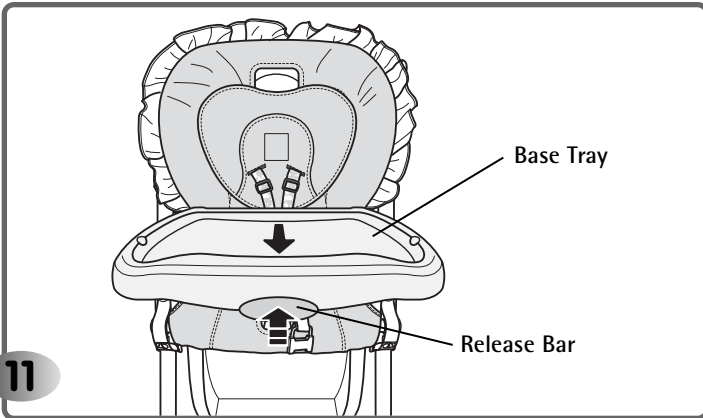

- While pushing the release bar on the front of the base tray, pull the tray base towards you and remove.

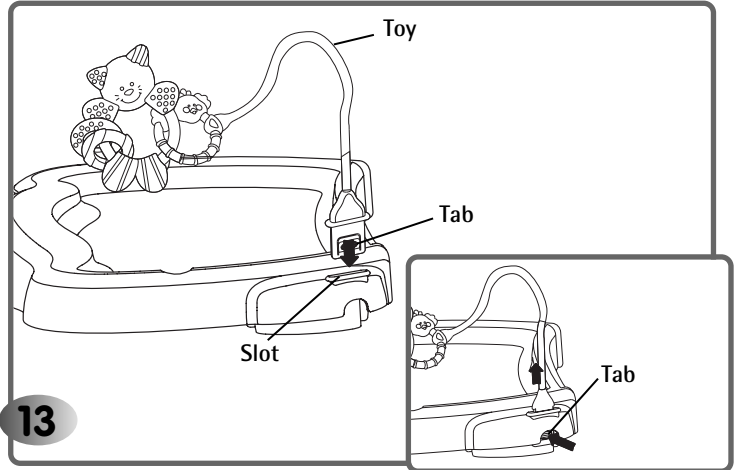

- Insert and "snap" either toy tab into either slot in the tray.

**Hint:** To remove a toy, press the tab and lift the toy.

## Adjusting the Seat

### WARNING

Prevent serious injury or death from falls or sliding out. It is recommended that the high chair be used in the upright position only by children capable of sitting upright unassisted.

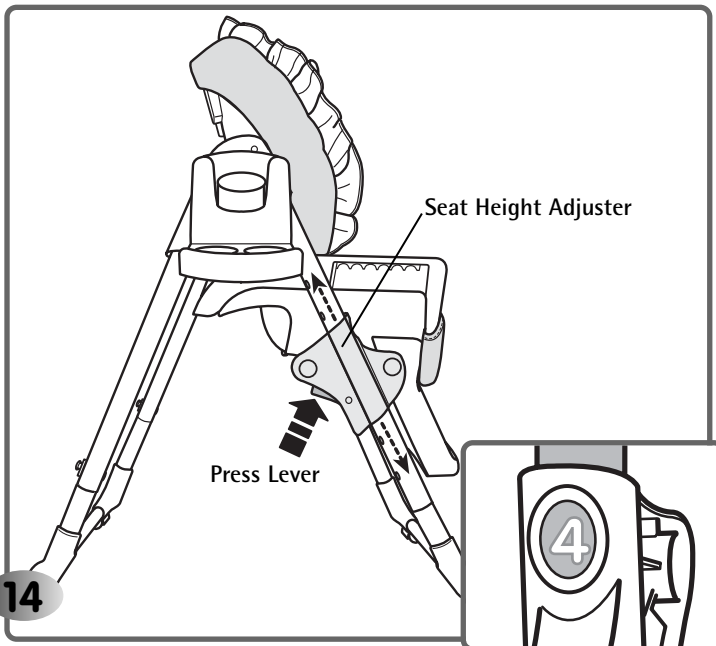

**Hint:** Adjust the **seat height** to any of seven positions!

To adjust the seat height:

- Press the levers on both seat height adjusters and lift or lower the seat to the desired height.
- Make sure both sides of the seat are adjusted to the same height. Push the seat bottom to be sure the seat is locked in place.

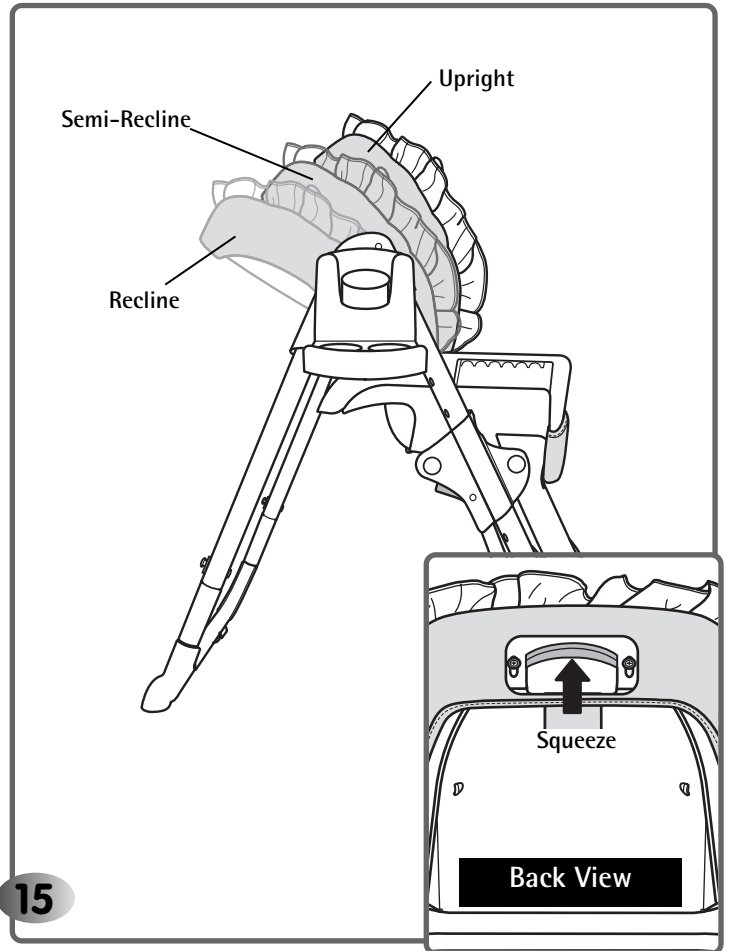

**Hint:** Adjust the **seat angle** to any of three positions: Upright, Semi-Recline or Recline.

To adjust the seat angle:

- Squeeze the seat back handle and push the seat back forward or, pull it backwards to the desired position.
- Push the seat back to be sure it is latched in position.



## Storage

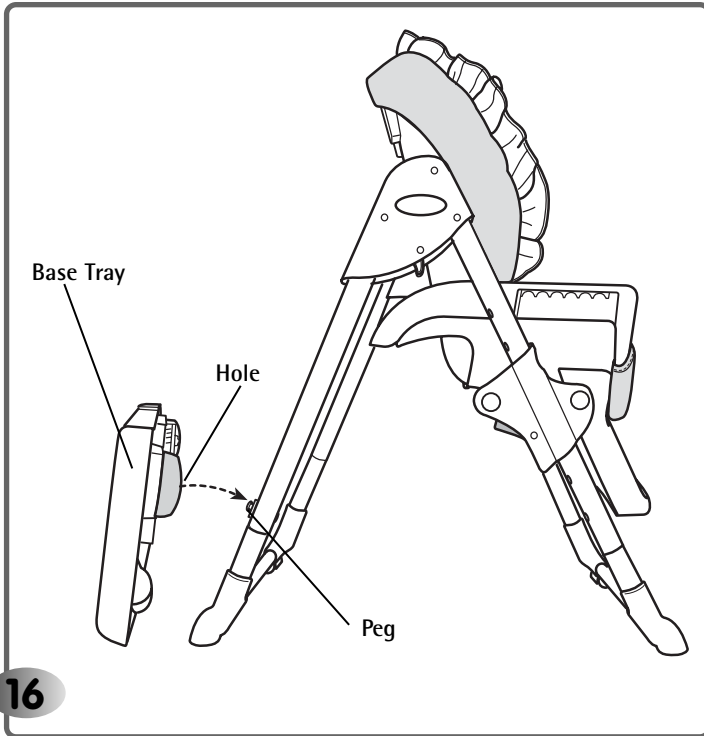

- Fit the holes on the base tray latches onto the pegs on the back of the high chair frame.

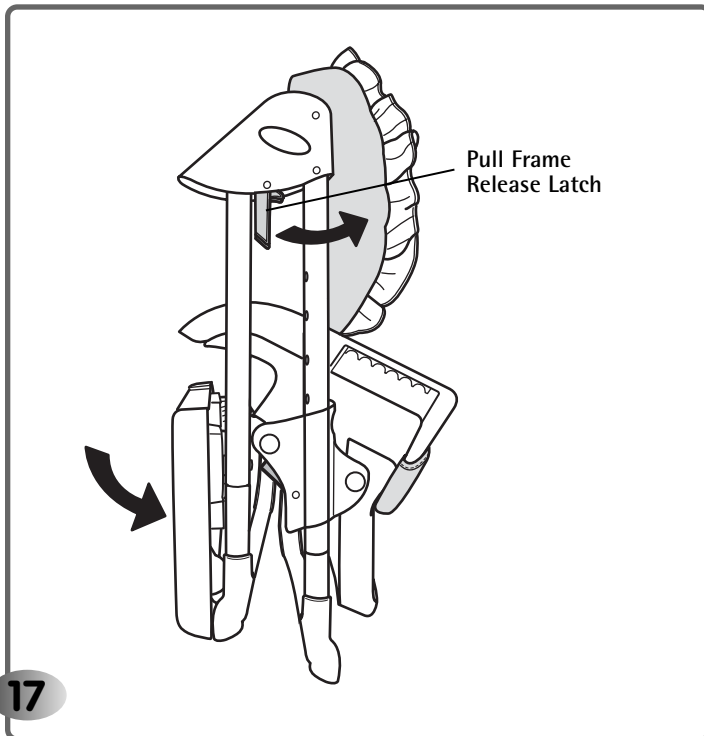

- With the legs all the way open, lower the seat to position 7 (the lowest position).
- Pull the frame release latches forward and push the rear legs toward the front legs.

## Care

- The pad and headrest are machine washable. Wash them separately in cold water on the gentle cycle. Do not use bleach. Line dry.
- The frame and base tray may be wiped clean using a mild cleaning solution and a damp cloth. Do not immerse the base tray.
- The food trays and toys are dishwasher safe. Simply remove the food tray from the base tray and place in your dishwasher.

### To remove the pad:

- Remove the four elastic loops from the pegs on the underside and back of the seat.
- Unfasten the pad strap from the seat back.
- Feed the shoulder portion of the waist/shoulder belts through the slots in the seat back and the pad.
- Feed the waist portion of the waist/shoulder belts and crotch belt down through the slots in the seat.
- Remove the waist/shoulder belts and crotch belt through the slots in the pad.
- Unfasten the pad fasteners from the front edge of the seat bottom.
- Remove the pad.
- To replace the pad: refer to Assembly steps 15-20.

**IMPORTANT!** Never use this product without the restraint system. Replace the waist/shoulder belts and crotch belt.

## Consumer Information

**Great Britain:** Mattel UK Ltd. Vanwall Business Park, Maidenhead SL6 4UB. Helpline: 01628 500302.

### Australia

Mattel Australia Pty. Ltd., 658 Church Street, Locked Bag #870, Richmond, Victoria 3121 Australia. Consumer Advisory Service 1300 135 312.

### New Zealand

16-18 William Pickering Drive, Albany 1331, Auckland.

### Asia

Mattel East Asia Ltd, Room 1106, South Tower, World Finance Centre, Harbour City, Tsimshatsui, HK, China.